

ETC-3

AVR Generator Automatic Voltage Regulator

Outline

ETC-3 automatic voltage regulator is applied to 50/60HZ brush excitation brushless excitation generator. Internal frequency compensation function (low frequency protection), automatic establish voltage function, EMI function (electromagnetic interference filter), Stability of the regulatory function, multi-voltage selector function, fuse protection function, Droop function and over excitation protection function; Suitable for voltage is 110 v, 220 v, 440 vac synchronous generator. ETC-3 using PMG as EXC. Power, make the performance better for generator loading.

Parameter

SENSING INPUT

Voltage Jumperselectable
100-130 Vac 2 phase 2wire or
190-264 Vac 2 phase 2wire
Frequency 50-60 Hz nominal

POWER INPUT (PMG)

Voltage 140-220Vac max, 3 phase, 3 wire
Current 3A/phase
Frequency 100-120 Hz nominal

OUTPUT

Voltage max 120V dc
Current continuous 3A
Intermittent 6A for 10 secs.
Resistance 15 ohms minimum
(10 ohms min when input
volts is less than 180 ac)

REGULATION

+/- 1.0% (With 4% engine)

TYPICAL SYSTEM RESPONSE

AVR response 20 mS

EXTERNAL VOLTAGE ADJUSTMENT

+/-10% with 1k ohm 1 watt trimmer

UNIT POWER DISSIPATION

12 watts maximum

ANALOGUE INPUT(A1,A2)

Maximum input +/-5 Vdc

Sensitivity 1v for 5% Generator Volts (adjustable)

Input resistance 1k ohm

QUADRATURE DROOP INPUT

Max. input: 0.33 A

OVER EXCITATION PROTECTION

Set point 75V dc

Time delay 10-15seconds (fixed)

ENVIRONMENTAL

Vibration 20-100 Hz 50mm/sec

100Hz ~2kHz 3.3g

Operating temperature -40to +70C

Relative Humidity 0-70C 95% ((De-rate

output current by 5% per degree C above 60C.))

Storage temperature -55to +80C

Over-current flow protection:

Built-in fuse holder, installed by the appropriate
fuse tube according to the actual demand.

Weight: 420g±5%g

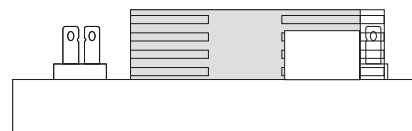
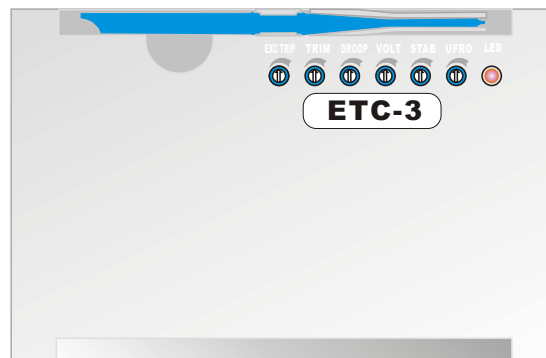
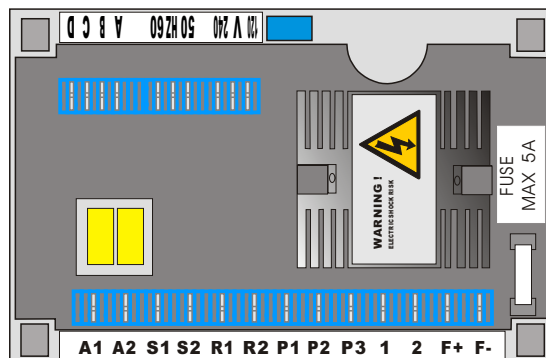

Outline drawing

Warning!

In order to avoid encourage personal injury or equipment damage , Non electrical professional or personnel didn't understand the product information on the content shall not be set and operating this product, if you have any questions please calling our company.

ETC-3

AVR Generator Automatic Voltage Regulator

Initial setup

ETC-3 have been detection of qualified by professionals before leaving the factory. In general use, only rotation the "VOLT" button for making the generator output voltage to reach the need voltage rating.

ETC-3: Speed protection knee point is 47HZ before leaving the factory. (50HZ model)

ETC-3: The initial voltage value is 380V before leaving the factory (according to the typical wiring diagram, the port "V" and "240" has been short-circuited).

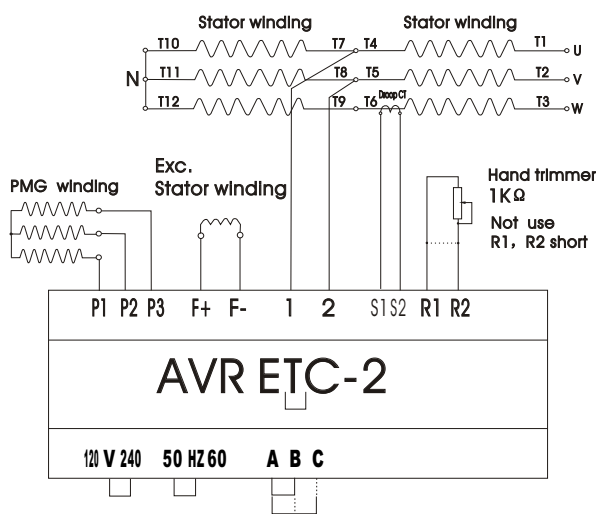

Stability Selection Table

Number	Power range	Response
A-C	< 100kW	Fast
B-C	100-550kW	Fast
A-B	> 550kW	Fast

Typical wiring diagram of the three-phase four-wire, 380V voltage mode

Wiring port description:

1. "50", "hz", "60" is the port for selection the generator frequency. The short-circuited "50" and "HZ" port for the 50 Hz use state; The short-circuited "HZ" and "60" port for the 60 Hz use state.
2. "120", "v", "240" is the port for selection generator checking voltage.
3. "R1", "R2" is the adjustable resistor port for remote generator 's voltage adjustment; the adjustable resistor must be 1 kilohm; without the adjustable resistor , the port must be short-circuited.
4. "F +", "F-" is the output port for export excitation power.
5. "1", "2" is the port for the AVR checking generator's voltage and the power for AVR.
6. "P1", "P2", "P3" is the port for AVR power input.
7. "S1", "S2" is the port for Droop CT input.
8. "A1", "A2" is the auxiliary control input port for the generator output voltage.

More AVR application and innovation please consulting the manufacturers.

Note!

You must disconnect all links between the post from "ETC - 3" and the generators are being tested before testing the withstand voltage and the insulation for generator windings.

"ETC - 3" have been installed the fuse base, please install the maximum current of the fuse for the generator when you using the "ETC-3? .

ETC-3

AVR Generator Automatic Voltage Regulator

Adjustment and setting

1. Voltage regulation: generator voltage adjustment can be adjusted by the "VOLT" on the AVR or by jumper adjustable resistor between port "R1" and "R2"; Clockwise "VOLT" adjustment can make the generator output voltage rise, reverse adjust "VOLT" can make the generator output voltage drop. Do not need to remote to adjust the generator output voltage, "R1" and "R2" must be short.
2. Stability adjustment: "STAB" clockwise to adjust for the generator output voltage tends to be stable, "STAB" reverse adjust generator output voltage tends to be unstable.
Slow adjustment "STAB" can change the response time between AVR and generator. Feedback time adjusted congress to make generator voltage instability. Adjust the response time shortly can make the full load generator fluctuation rate increase in an instant. The appropriate Settings can be reduce the generator voltage fluctuation rate with fully loaded.
3. Low frequency protection: "UFRO" is used to set the low frequency protection of knee point, the position of "UFRO" generally do not need to set. "UFRO" before leaving the factory setting is: Frequency 50 hz ac model of knee point for the protection of the 47 hz, frequency 50 hz ac model of knee point for the protection of the 47 hz. If need setting, first , start the generator, and turn the rotational speed of the generator to the position of Low speed protection frequency, adjust "UFRO" to the LED light.
4. Droop adjustment: When the generator for parallel use, must be connected one CT to the "S1" and "S2" port on the AVR, adjust "DROOP" can change the voltage drop rate of generator voltage. "DROOP" clockwise adjustment, the largest decline is 5% of the rated voltage; Reverse adjust "DROOP", the smallest decline is 0% of the rated voltage.
5. Voltage dressing: Supply dc signal to the "A1", "A2" port on the AVR to modify the AVR setting voltage. Clockwise adjustment "TRIM", bigger influence on the generator voltage, reverse adjust "TRIM", smaller influence on the generator voltage.
6. "EXC TRIP" for shunt voltage protection Settings button, clockwise raise generator excitation voltage protection, counterclockwise to lower generator excitation voltage protection.